

Model weco 01 to 250

Powerful and reliable.

Also for high ambient temperatures.



gwak

Compact packaged chillers



Compact chiller model **weco 07 A** with air-cooled condenser

Innovative technology

The new compact chillers are equipped according to the latest developments in technology. The use of powerful compressors together with standard designed components in the refrigerant circuit guarantees a high efficiency. Consequently the units are running at low operating costs, have a high reliability and long life.

The overall technical design of the unit and the precise measurement and control technology coupled with tailor made microprocessor control enable a high temperature stability for every application. The high capacity together with a compact footprint enable the chiller to be sited even in restricted areas.

Environmentally friendly

As a specialist manufacturer of energy-saving technology we are taking responsibility for the environment. For many years we have led the way in developing equipment using environmentally friendly refrigerants.

Therefore we decided to equip all our new products with the environmentally friendly refrigerant R134a, which avoids any risk for the ozone layer. A further advantage of R134a is its behaviour at high ambient temperatures – every production manager will appreciate the better performance and the higher reliability during hot summer days.



Compact chiller model **weco 250 AZ** with air-cooled condenser

Quality guaranteed

All our chillers are quality products and the result of more than 35 years of experience in industrial cooling. Many units that have been delivered to machine manufacturers still work after more than 20 years under the toughest operating conditions. Important elements of our quality philosophy are:

- In-house development and manufacturing with skilled labour only.
- Exclusive use of renowned high quality components.
- Corrosion resistant materials for all water contacted components.
- Trial run before delivery on one of our test banks.
- Certified manufacturing procedures according to DIN ISO 9001.



Technical features

The design details of the compact weco range emphasize our technical know-how.

- Cooling circuit with environmentally friendly refrigerant R134a.
- Suction gas-cooled efficient compressors with low energy consumption, designed as fully hermetic piston type compressors within the weco range 01 to 03, as fully hermetic scroll compressors within the weco range 11 to 71, as semi hermetic reciprocating piston compressors within the weco range 85 to 120 and as semi hermetic, continuously controlled screw compressors within weco range 145 to 250.
- Electronically controlled crankcase heater to avoid any damage to the compressor caused by fluid refrigerant in the oil sump of the compressor.
- Ready to plug in unit delivered with refrigerant and oil.
- Comprehensive safety chain to protect the units including filter dryer, sight glass with moisture indicator, high and low pressure switch, frost safety thermostat and flow switch.
- Large scaled evaporators, designed as copper coil for the weco 01 to 03, as coaxial evaporator for the weco 07 to 09, as plate evaporators for the weco 11 to 35 and shell and tube evaporators for the weco 48 to 250.
- Air-cooled condensers and as an option water-cooled condensers with high exchange surface only available from weco 07.
- Powerful fan with pressure control.
- Microprocessor control with membrane type keyboard and clear text indication.

- Stainless steel water tank with level control and dry running protection for the pump.
- Powerful pumps and water circuits designed with corrosion free materials.

We offer a large number of useful options to adapt the compact chillers to the application or the special needs on site.

- Radial fan to connect the chiller to an existing air duct system available from weco 11. The air duct may be used to transport the air to the outside of the building or to heat the building.
- Additional water-cooled condenser for heat recovery.
- Condenser in split version for outdoor installation, for weco range 35 to 250.
- Additional equipment for outdoor installation of the complete chiller.
- Tropical insulation for installation in hot climates with high humidity.
- Communication modules for all common interfaces and remote stop/start.
- Special voltage.
- Individual painting in RAL colours.
- Fittings and flexible tubes.



Compact chiller model **weco 15 WB** with water-cooled condenser

Technical information at a glance

Model weco	cooling capacity at outlet temp. 15 °C (kW)	Coefficient of performance	power input* (kW)	standard pump		dimensions L x W x H (mm)	weight max. (kg)
				max. flow (m ³ /h)	max. pressure (bar)		
01	1.5	-	0.7	3.6	3.8	777 x 735 x 1100	140
03	3.0	-	1.4	3.6	3.8	777 x 735 x 1100	140
07	7.4	5.3	2.1	4.2	4.5	777 x 835 x 1253	160
09	9.0	5.2	2.6	4.2	4.5	777 x 835 x 1253	170
11	9.0	5.3	2.6	4.2	4.5	1110 x 1060 x 1830	330
15	15.0	5.5	4.1	4.2	4.5	1360 x 1060 x 1830	380
24	23.5	5.3	6.5	7.2	6.0	1360 x 1060 x 1830	410
35	33.0	5.2	9.3	7.2	6.0	1900 x 1060 x 1830	790
48	47.0	5.3	13.1	9.0	6.3	2150 x 1215 x 2035	950
59	57.5	5.2	16.0	12.0	5.3	2150 x 1215 x 2035	1030
71	69.0	5.3	19.1	12.0	5.3	2150 x 1215 x 2035	1050
85	86.0	4.3	25.6	30.0	5.5	2650 x 1215 x 2035	1340
100	102.0	4.4	29.5	30.0	5.5	2650 x 1215 x 2035	1380
120	118.0	4.3	35.7	30.0	5.5	2650 x 1215 x 2035	1500
145	146.0	5.0	39.3	45.0	4.6	3825 x 1750 x 2350	2550
170	171.0	5.4	44.5	48.0	5.7	3825 x 1750 x 2350	2600
190	190.0	5.2	50.9	48.0	5.7	3825 x 1750 x 2350	2650
230	226.0	5.5	56.6	48.0	6.3	4645 x 1750 x 2350	3200
250	251.0	5.2	65.7	84.0	5.0	4645 x 1750 x 2350	3250

*power input at 40 °C air-/cooling water temperature

Subject to technical modification without notice!



Compact chiller model **weco 48 AB** with
air-cooled condenser and axial fan

Compact packaged chillers – efficient and environmentally friendly

Many industrial processes require the supply of heating or cooling energy. The excess process heat in the consumer is specifically extracted by means of cold water. The process quality is directly dependent on the stability of the cooling water temperature.

Due to varying conditions found both on the production site and within the environment globally producing constant cold water can only be achieved by the use of independent cold water

chillers. In the low and middle capacity range this is the main application for compact packaged chillers.

In the protection of the environment it makes sense to use recirculating water chillers. Together with the global industrialization the cooling water consumption in nearly every branch of industry is increasing. Shortage in water and the related increasing water costs in combination with stronger regula-

tion of waste water control increases the need for these systems. The decision for the environment is easy because the chillers also offer possibilities to save on running costs. Also the recirculating high productivity chillers offer much lower operating and service costs than open systems resulting in a decrease in the cost of production.

Available systems

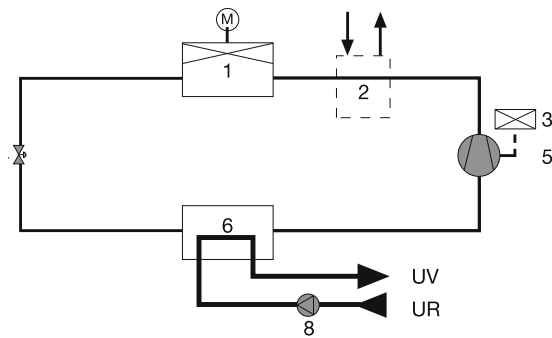

Basic Design (G)

Packaged chiller with pump, but without internal water tank, ready for use together with open consumer circuits such as existing cold water storage tanks or extrusion baths.

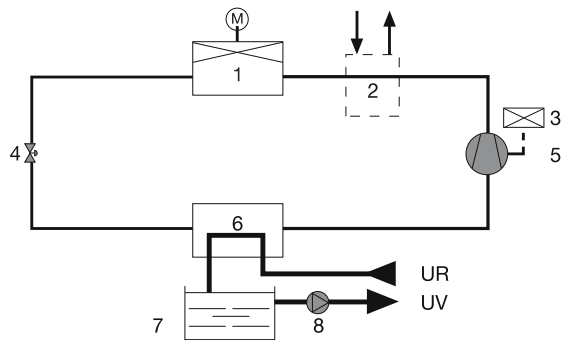

Standard Design (B)

Packaged chiller with pump and internal water tank. Ready for connection to cold water systems like mould cooling or hydraulic cooling of single injection moulding presses.

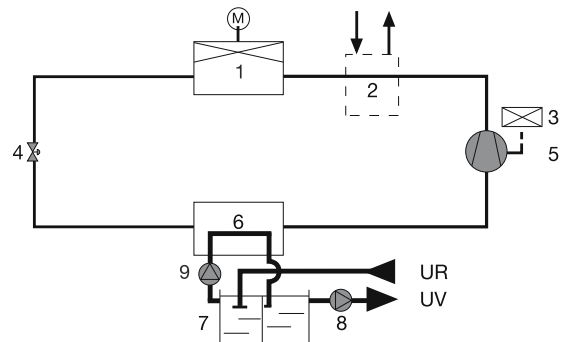

Central cooling plant (Z)

The unit is equipped with two pumps and a water tank with cold and hot water section. We recommend the use of this version together with several consumers and high variations in the cooling load of the connected system.

Legend: 1 = condenser / 2 = additional heating condenser* / 3 = temp. regulator / 4 = expansion valve / 5 = compressor / 6 = evaporator / 7 = water tank / 8 = process pump / 9 = evaporator pump / UV = to consumer / UR = from consumer
 — = cold water circuit / — = refrigerant circuit / * = option

gwk Perfect cooling and temperature control

Increasing productivity

In many areas of the industry, cooling and temperature control provides a great potential for increasing productivity and thus for lowering costs.

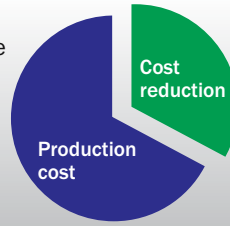

Many factors serve to improve productivity:

- Reduction of cooling time, therefore savings in required machine hours
- Improvement of product quality
- Increasing availability of production plants
- Decreasing running cost
- Reduction of maintenance cost

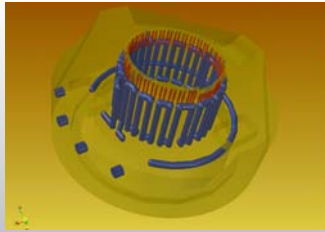

gwk integrat 4D

Optimal product quality through homogeneous temperature distribution with close-to-cavity cooled mould inserts.



gwk KU plants

The simplest and cheapest solution to increase the availability and to decrease the maintenance cost of open cooling systems.



gwk system integrat

Increase of productivity by means of specific and segmented control of the mould cooling.



gwk hermeticool hybrid

Innovative cooling system to decrease the running and maintenance cost in comparison to conventional cooling systems.



gwk teco cw

Most economic system to extract heat from consumers at very low temperatures by patented cold water temperature control.



gwk container plants

Highest flexibility and lowest expenses for planning installation and movement of a centralised cooling plant.



gwk SKL / SKW

Reliable and economic supply of cooling water in the low temperature range, even under the toughest ambient conditions.



gwk active

Adjusting and maintaining optimum capacity by means of constantly clean water, delivered from a fully automatic water treatment device.



gwk HSW

Cost reduction by means of advanced heat recovery systems.



gwk service

Decreasing the maintenance cost and protection of company owned resources through professional installation and service including maintenance of cooling water.

gwk